



features and benefits:

- 50mm silver extrusion frame
- Single-sided SEG dye-sublimated push-fit fabric graphics
- Counter available in four thermoform finishes, shown below

- ~~HTXO~~DMVEFTGSBNFEHTVCM~~BUFE~~
HSBQ~~GPVSBDDFOUX~~HTUXPXBUU
M~~IUTDPVOUFSBOEUXPXIFFMFENPMEFEDBTFT~~
- ~~FU~~FIBSEXBSFXBSSBOU~~HB~~TU
NBOVGBDUVSFSEFGFDUT

dimensions:

Hardware	Graphic
<p>Assembled Unit: 117" w x 102" h x 23" d 2972mm(w) x 2591mm(h) x 584mm(d)</p> <p>Counter: 38.5" w x 40.5" h x 19.88" d 978mm(w) x 1,029mm(h) x 505mm(d)</p>	<p>Refer to related graphic templates for more information</p>
<p>Shipping</p> <p>Shipping Dimensions - ships in 2 cases: 1 OCH2 case: 52" l x 29" h x 15" d 1321mm(l) x 762mm(h) x 381mm(d)</p> <p>1 OCE case: 18" l x 40 - 66" h x 18" d 457mm(l) x 1016mm - 1676mm(h) x 457mm(d)</p> <p>Approximate shipping weight (entire kit): 162.5 lbs / 73.7 kgs</p>	

additional information:

Graphic material:
Dye-sublimated fabric

Tabletop color options:



silver



black



mahogany



natural

Lights Included:
Lumina 200 120 watt floodlight, curved arm, black finish, 19.5" from end to end

Counter holds max weight
100 lbs / 45.4 kgs

We are continually improving and modifying our product range and reserve the right to vary the specifications without prior notice. All dimensions and weights quoted are approximate and we accept no responsibility for variance. E&OE. See Graphic Templates for graphic bleed specifications.

Parts Included:

Code	Qty	Description
VF-K-09-A-G	x1	300MM (11.81")W X 1150MM (45.27")H PVC GRAPHIC
VF-K-09-B-G	x1	300MM (11.81")W X 1150MM (45.27")H PVC GRAPHIC
VF-K-09-C-G	x1	2522MM (99.3") X 2400MM (94.5")H FABRIC GRAPHIC W/FCE-2 ALL SIDES
VF-K-09-D-G	x1	300MM (11.81")W X 1150MM (45.27")H PVC GRAPHIC
VF-K-09-E-G	x1	300MM (11.81")W X 1150MM (45.27")H PVC GRAPHIC
F52	x4	8R PHFC2 EXTRUSION WITH LOCK ONE SIDE - WITH IB2 LOCK HOLES ONE SIDE
F34	x4	1155MM (45.47") PHFC2 EXTRUSION - WITH IB2 HOLE ONE SIDE - WITH LOCK ONE END
SW-FOOT	x2	VECTOR FRAME SUPPORT FOOT
IB2	x5	PH INLINE CONNECTOR
CB9-R	x2	50MM ROUND PHCF2 CORNER BRACKET
CB9-S	x2	50MM SQUARE PHCF2 CORNER BRACKET
LUM-200-ORL-B LN-3P-LT-FXT	x2	BLACK 200W HALOGEN LIGHT FIXTURE ETL APPROVED
VE-70	x2	1155MM (45.47") PH EXTRUSION WITH IB2 HOLE ONE SIDE - WITH LOCK ONE END
PANEL CLAMP	x8	7MM PLASTIC MOLDED PANEL CLAMP

VF-K-09

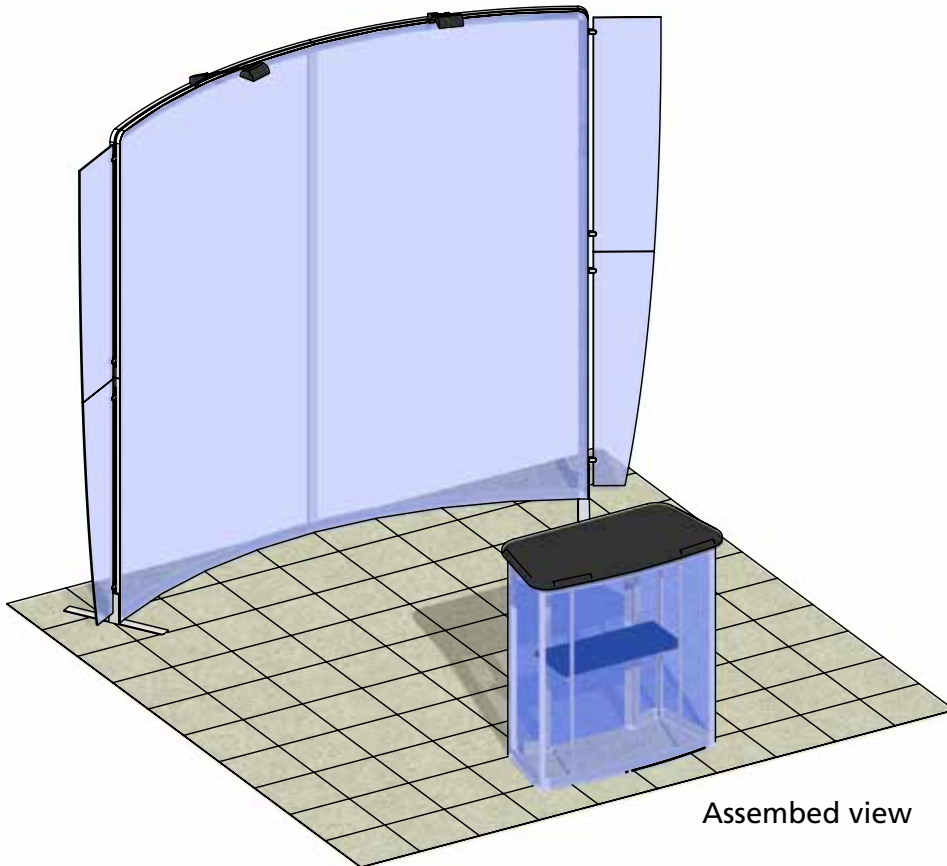
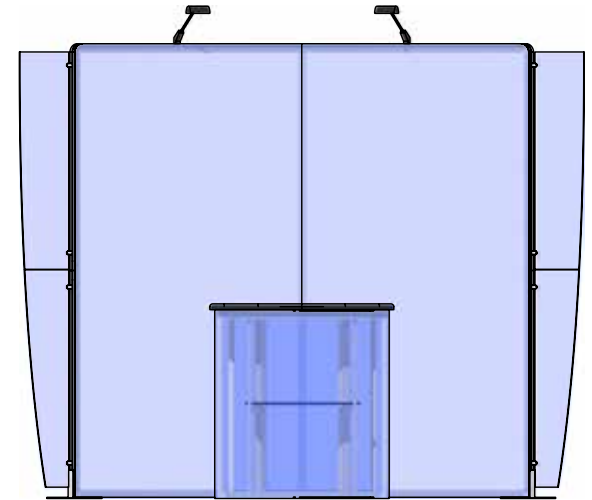

Assembled view

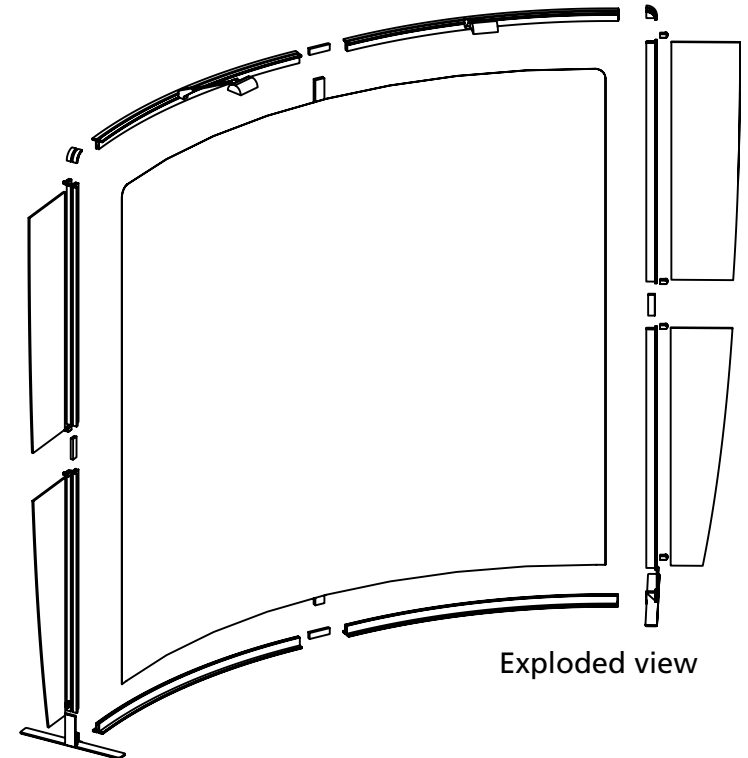

Exploded view

Step 1: Assemble Center Frame

Arrange pieces on the floor as shown in the diagram below. Assemble frame by securing CB9-R's on the top and CB9-S's on the bottom to the F52 and F34s. When locking be sure to turn each cam a little bit and then go back and tighten to the proper tension. Take care to turn locks only half a turn. Slide the IB2 into the extrusion to connect sides. Tighten to the proper tension to lock extrusions together. To adhere foot to frame, loosen thumbscrews from foot. Slide extrusion into LN-100 groove. Tighten to the proper tension to secure supporting feet.

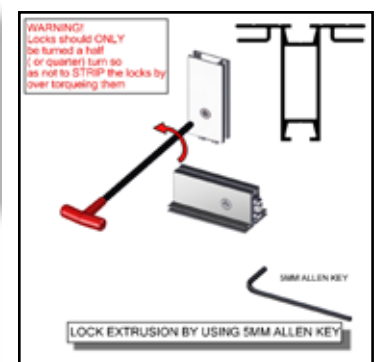
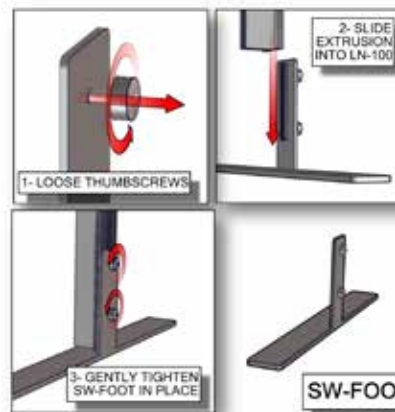
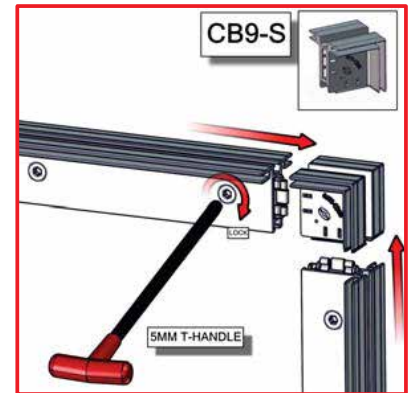
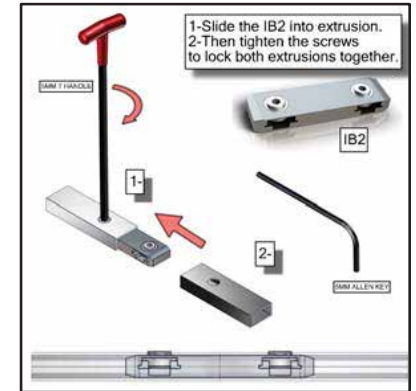
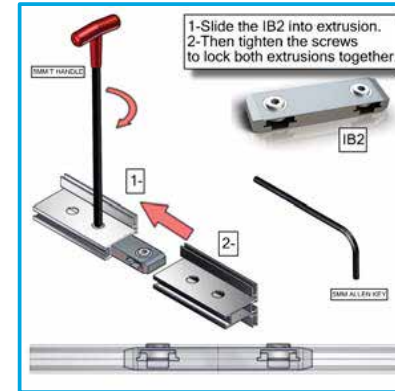
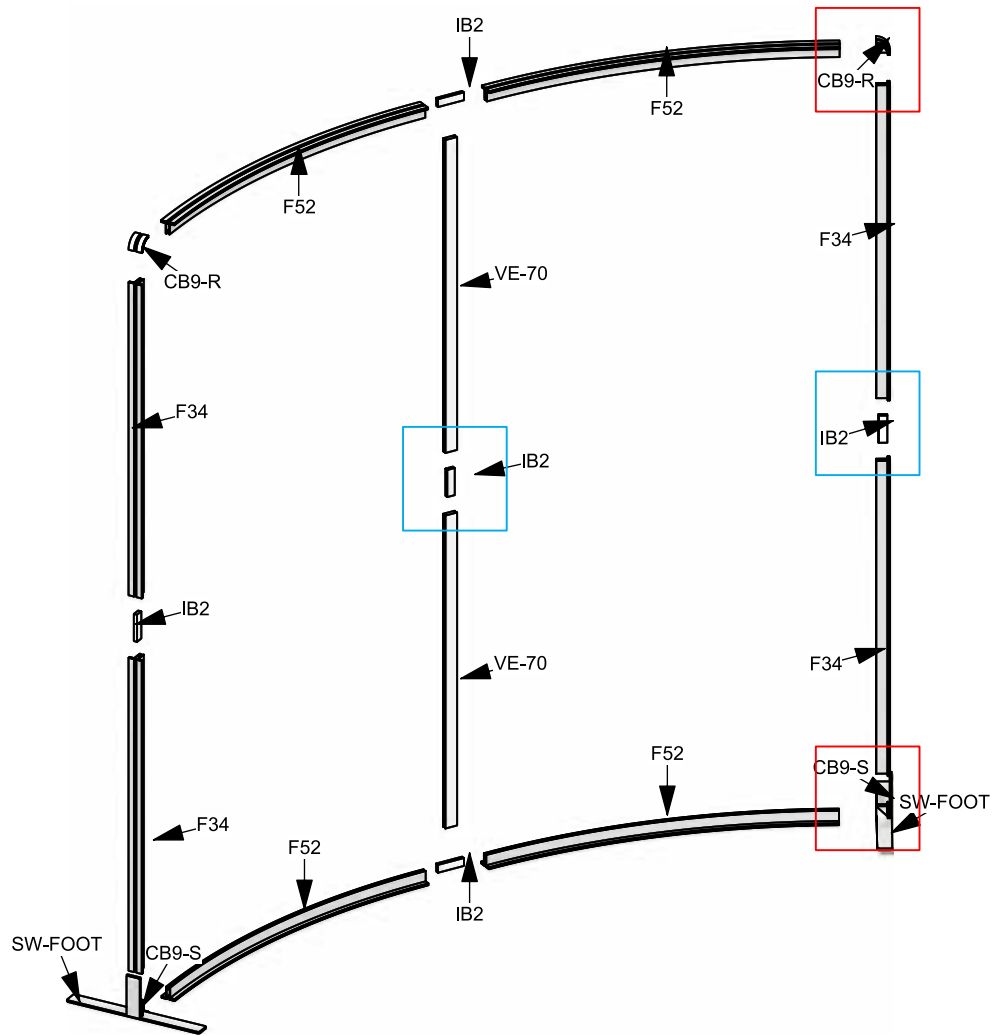

Step 2: Apply Center Panel Graphics

Install graphic(s) by pressing the FCE-2 edge of graphic into the channel of the extrusion. Start in upper left corner and insert in remaining corners, then push graphic into each side. Assure graphic is tightly inserted. When taking graphics off, take care to gently pull by attached pull tab.

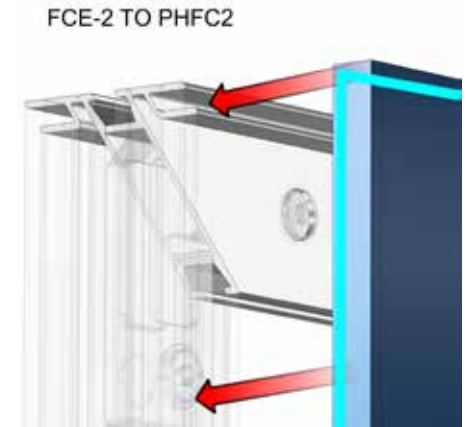
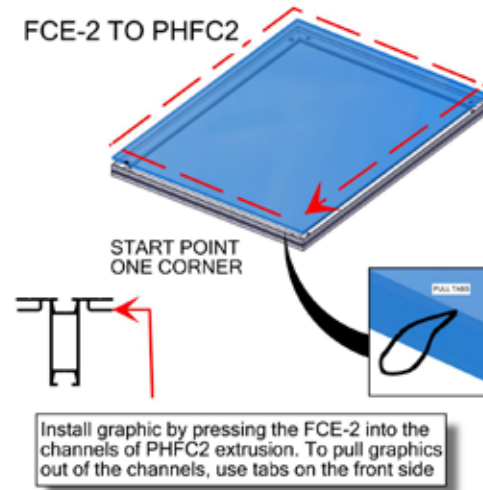
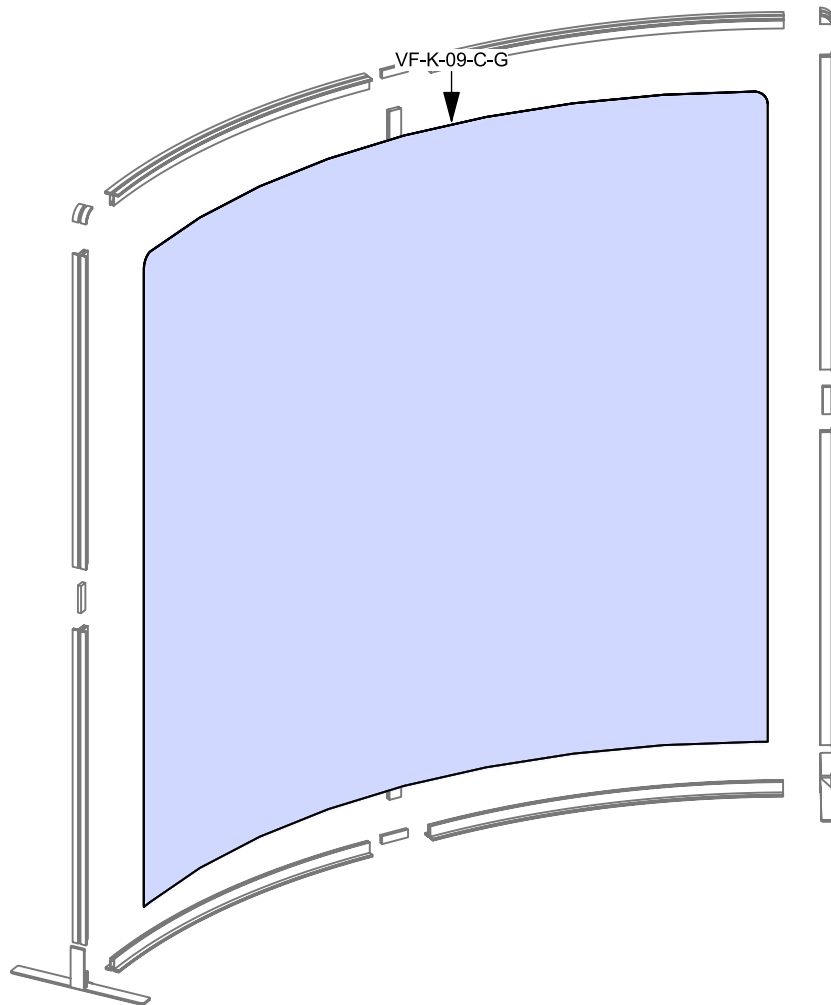

Push fabric with FCE-2 edge folded over into each corner of frame.



Press into the middle of the inside channel and continue around perimeter.



To remove graphic, use the pull tab and gently pull graphic from frame.

Graphic Storage & Care: Graphics should be folded with the graphic facing inward and stored in a ziplock / sealable plastic bag. Spot clean by wiping with a damp white cloth. If washing is necessary, use a commercial size front-loading washing machine, gental cycle with cool water. Line dry flat. Dry cleaning is NOT recommended to prevent shrinkage.

Step 3: Attach Accent Wings & Lights

To attach accent wings, screw panel clamp clockwise, into the channel until it is tight. Loosen the thumbscrew. Place rigid sintra graphics into place and tighten thumbscrew to secure. Slide light clip onto each light. Then slide light into the extrusion channel at an angle and gently lower down and repeat for each light.

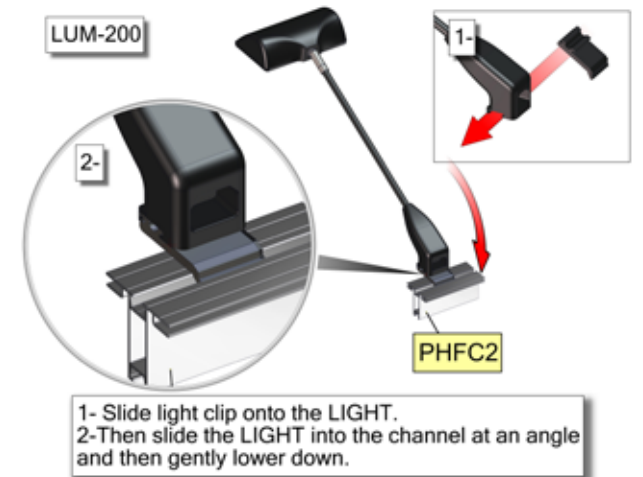
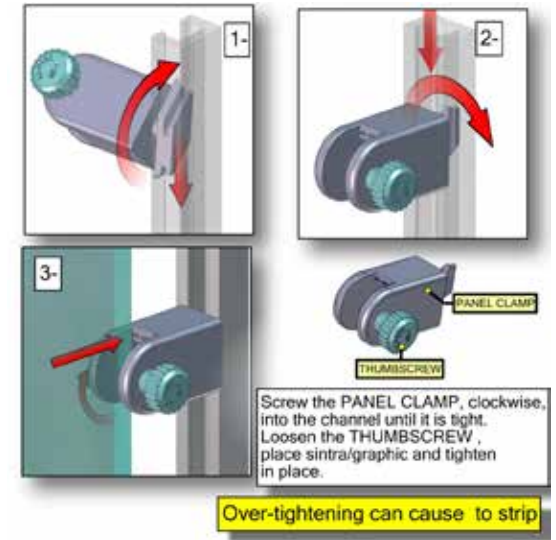
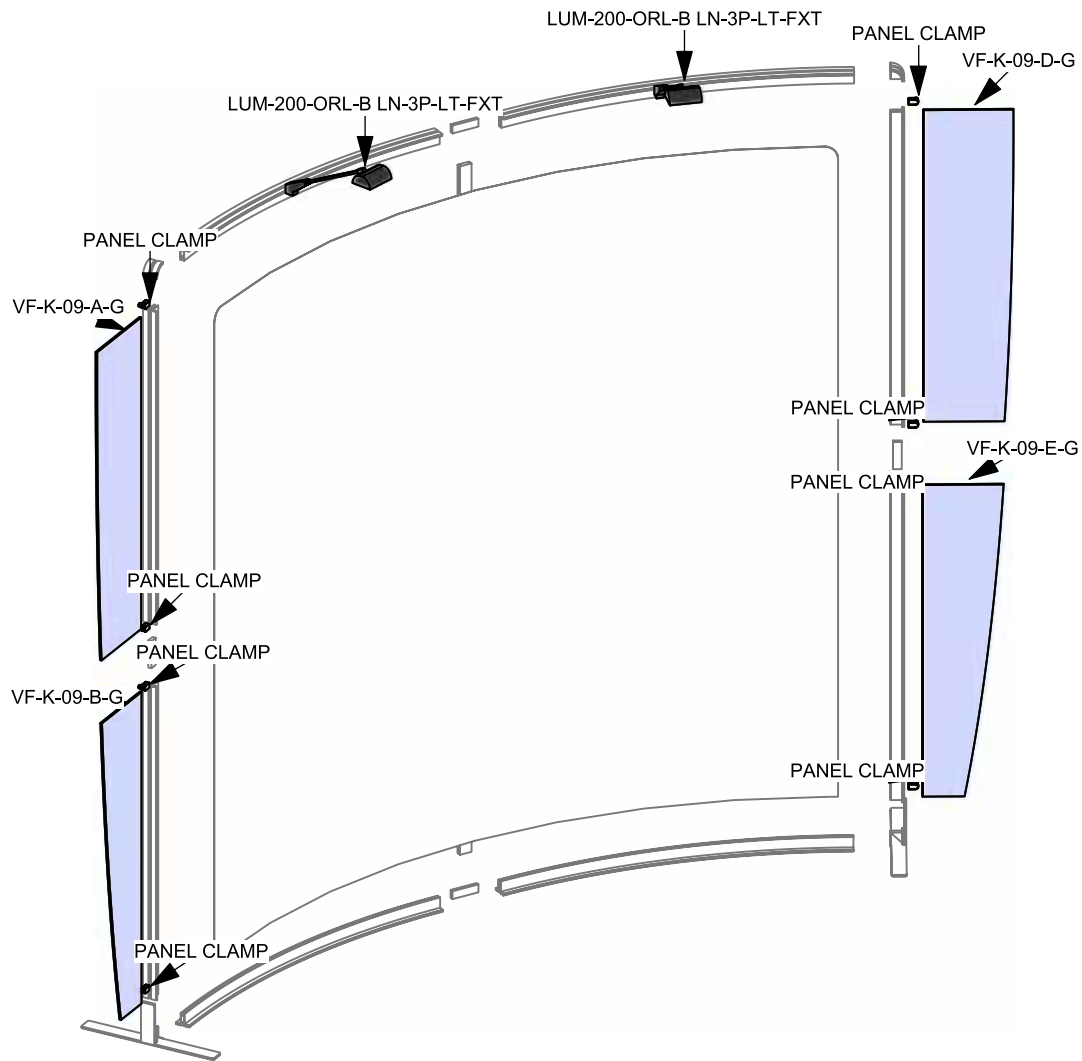

Parts Included:

Code	Qty	Description
F54	x2	8R X 20 DEGREE PHFC2 EXTRUSION - WITH CAM LOCKS BOTH ENDS
F43	x4	300MM (11.81") PHFC2 EXTRUSION WITH LOCKS TWO ENDS
F48	x4	100MM (3.94") PHFC2 EXTRUSION WITH LOCKS TWO ENDS
F24	x2	986MM (38.32") PMFC2-90 EXTRUSION - WITH IB2 LOCK HOLES BOTH SIDES
CB10-R	x8	50MM ROUND PHCF2 CORNER BRACKET
VFC-03-CT	x1	COUNTERTOP FOR VECTOR COUNTER VFC-03
VFC-03-CT-S	x1	INTERNAL SHELF FOR VECTOR COUNTER VFC-03
VFC-03-B-G	x1	362MM (14.92")W X 1000MM (39.38")H FABRIC GRAPHIC W/FCE-2 ALL SIDES
VFC-03-A-G	x1	2087MM (82.17")W X 1000MM (39.38")H FABRIC GRAPHIC W/FCE-2 ALL SIDES
TUBE-30-910	x4	910MM (35.82") X 30MM TUBE WITH E530 HOLES BOTH ENDS
PMFC2-90 CAP	x4	PMFC2 90 DEGREE EXTRUSION CAP
VE-80	x4	288MM (11.34") PH1 EXTRUSION WITH LOCKS BOTH SIDES
PE-1000	x2	1000MM (39.38") PE EXTRUSION

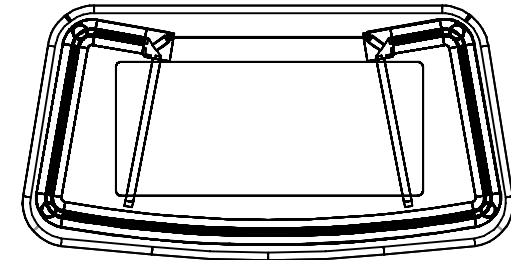

Overhead view

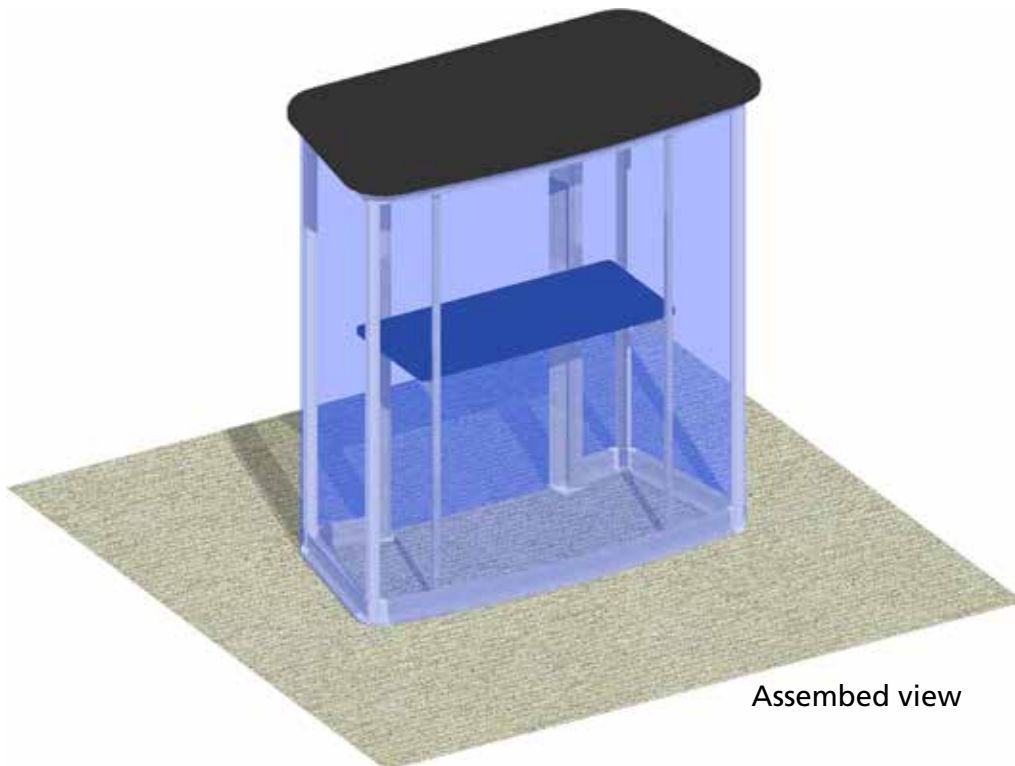

Assembled view

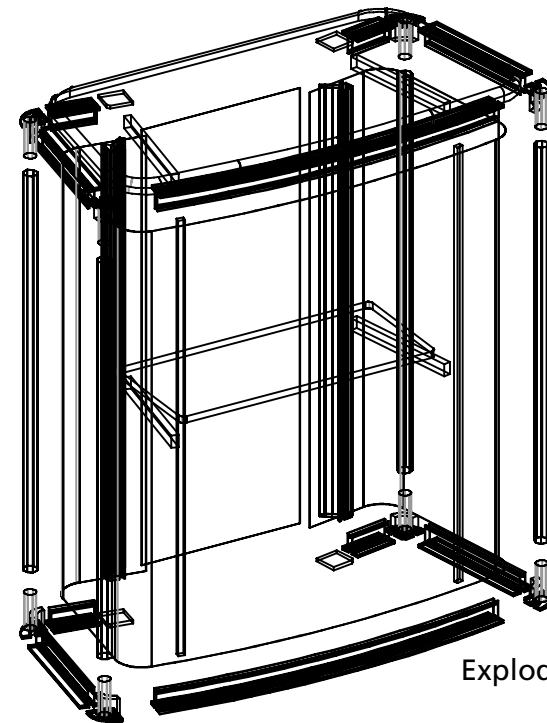

Exploded view

Step 1: Assemble Counter Frame

Arrange pieces on the floor as shown in the diagram below. Assemble frame sides by securing CB10-R to F43 and TUBE-30-910. Continue frame assembly by locking F48s, F54s and F24s to extrusion. When locking be sure to turn each cam a little bit and then go back and tighten to the proper tension. Take care to turn locks only a quarter turn, so as to not strip the locks by over tightening.

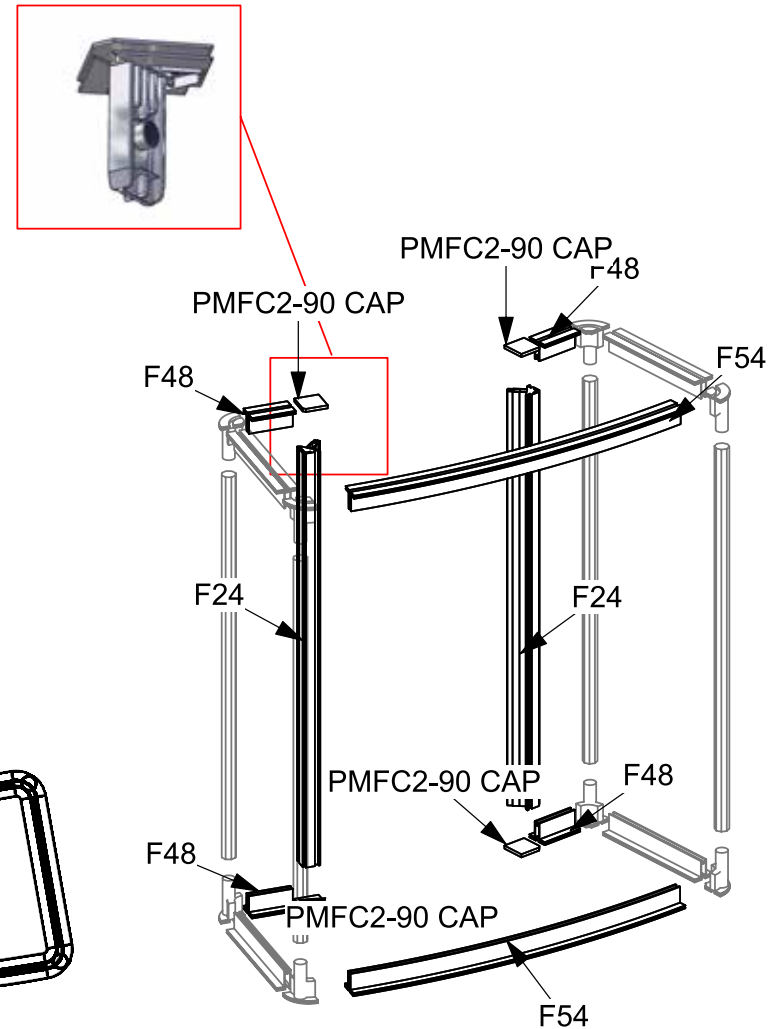
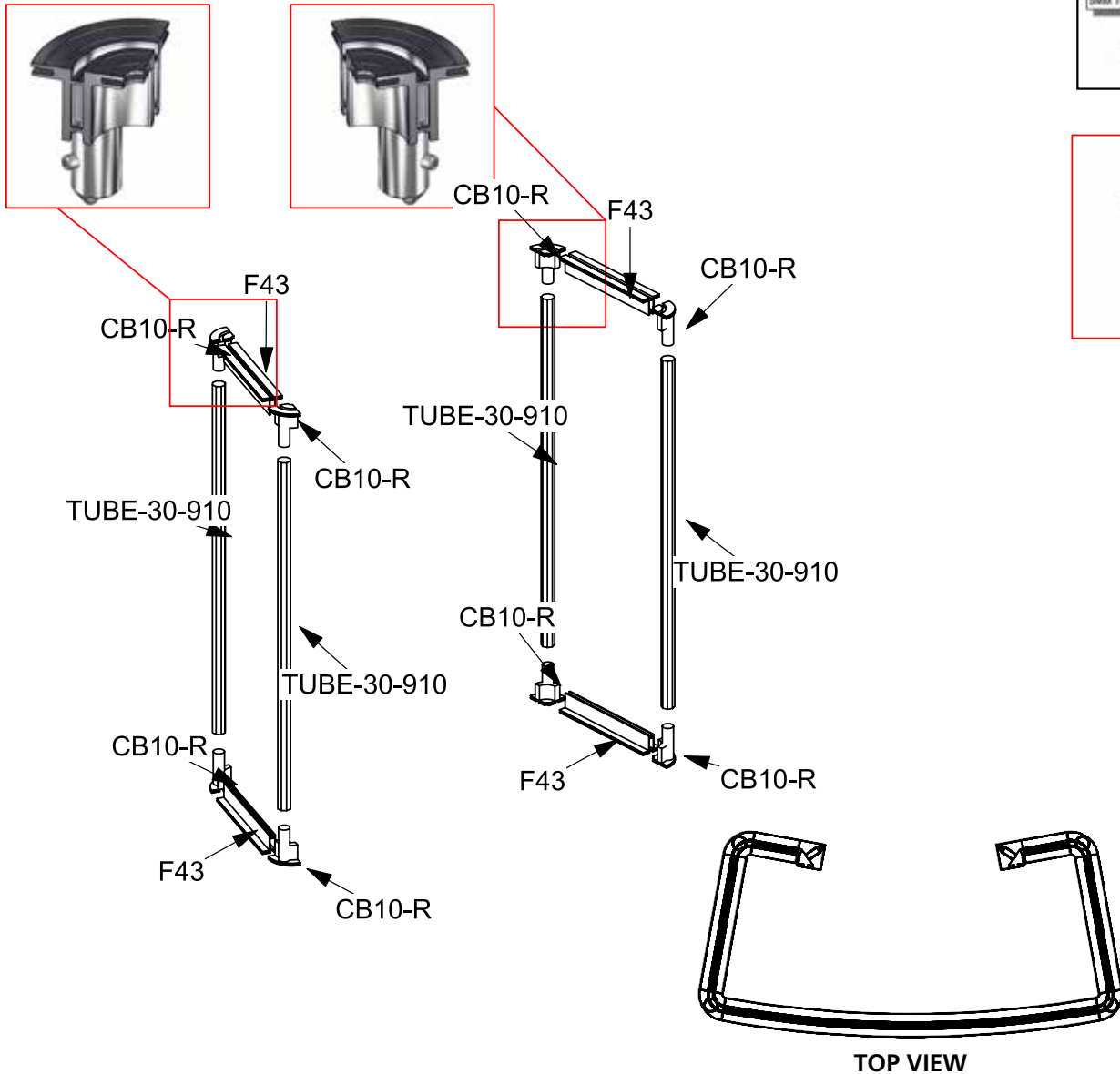

Step 2: Install Internal Shelf

Assemble shelf support frame by securing VE-80 to PE-1000 extrusion. With VE-80 secured to PE-1000, slide PE-1000 into counter frame as shown below. Lock each frame to F-24 using Allen Key. Install internal shelf (VFC-02-CT-S) on top of VE-80s.

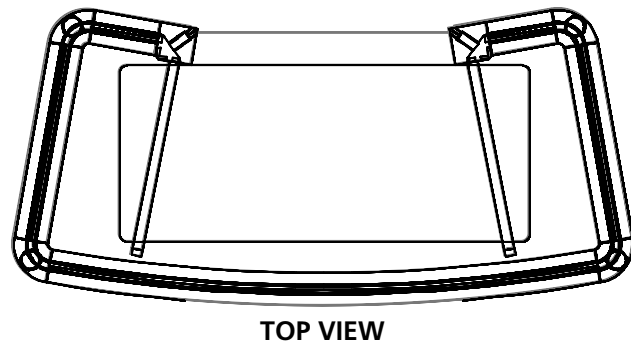
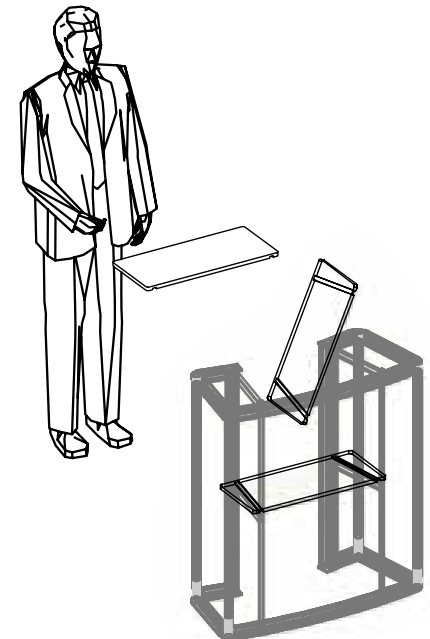
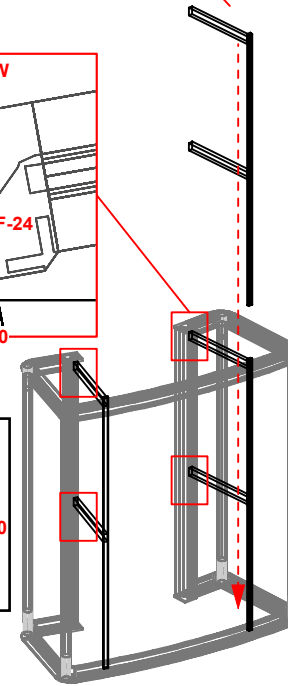
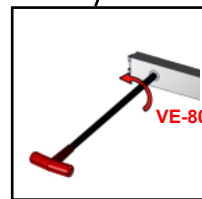
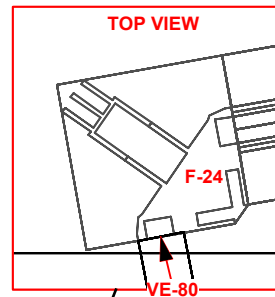
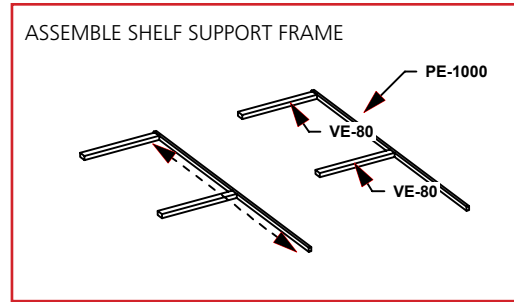
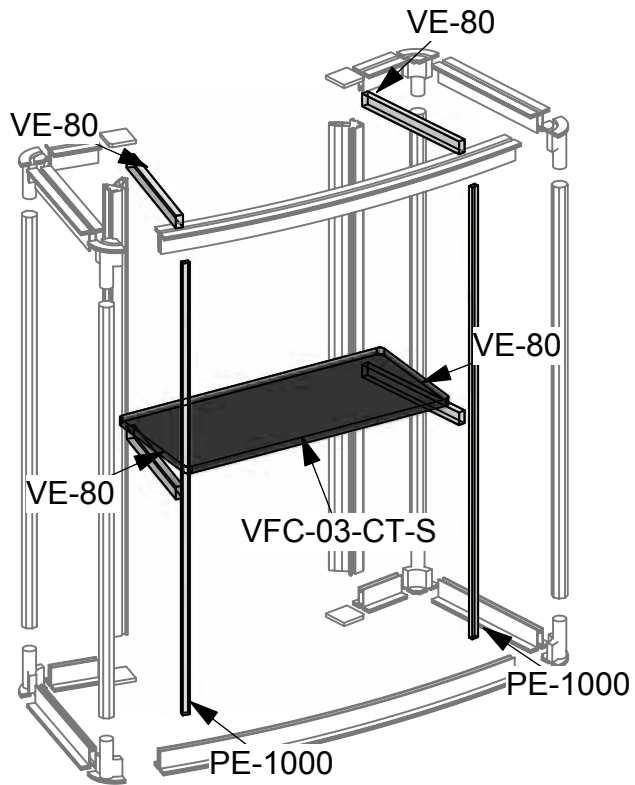

Step 3: Apply Graphics & Attach Countertop

Apply push-fit fabric graphic(s) by pressing the FCE-2 edge of graphic into the channel of the extrusion. Start in upper left corner, go across the top and then down the sides to the bottom. Repeat for each side. Assure each graphic is tightly inserted. When taking graphics off, take care to gently pull by attached pull tab. Next, gently place the countertop onto the completed frame. Lock countertop into place using Hex Key.

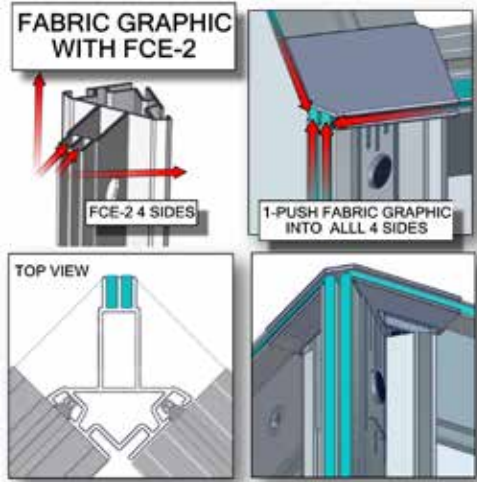

Push fabric with FCE-2 edge folded over into each corner of frame (1-4).



Press into the middle of the outside channel (5-8) and continue around perimeter.



To remove graphic, use the pull tab and gently pull graphic from frame.

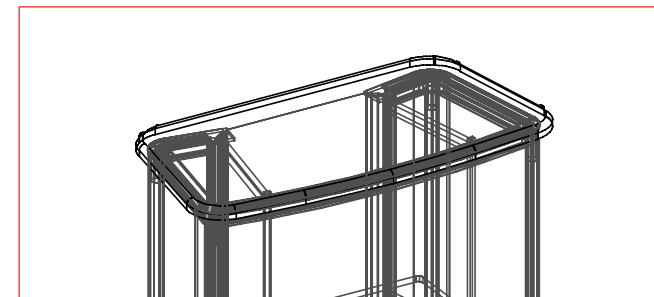
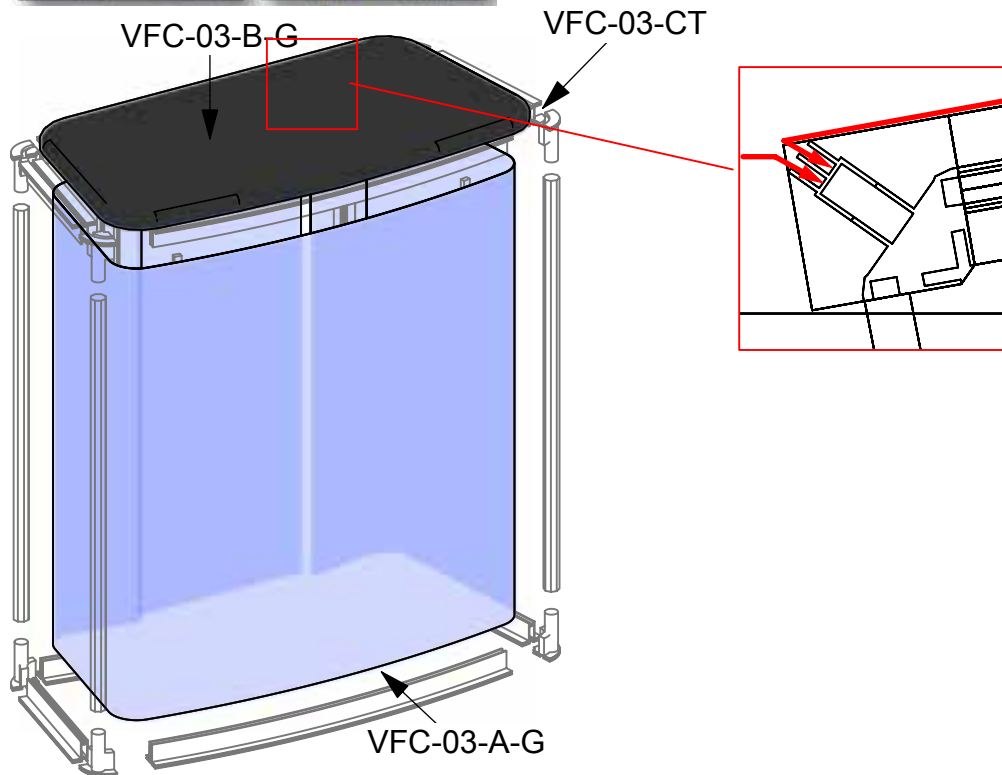

VFC-03-CT

