

# TensionLite Mini-Wall Straight Design 1500

TensionLite displays feature basic tubular frames coupled with pillowcase fabric graphics. The economy tube frames come with a one year limited warranty. Simply pull the graphic over the frame.



## features and benefits:

- Straight aluminum tube frame
- Easy to store and ship
- Quick to set up
- Pillowcase fabric graphic
- Carry bag included
- Bungee cords for easy assembly
- One year limited hardware warranty against manufacturer defects

## dimensions:

Hardware	Graphic
Assembled unit: 33.85"w x 94.5"h x 14.2"d 860mm(w) x 2400mm(h) x 360mm(d)	Refer to related graphic template for more information.
Shipping	
1 carry bag	
Shipping dimensions (box): 34"l x 8"h x 6"d 867mm(l) x 204mm(h) x 153mm(d)	
Approximate total shipping weight (includes carry bag and graphics): 13 lbs / 6 kgs	
<b>additional information:</b>	
Graphic material: dye-sublimated slip-over graphics	

We are continually improving and modifying our product range and reserve the right to vary the specifications without prior notice. All dimensions and weights quoted are approximate and we accept no responsibility for variance. E&OE. See Graphic Templates for graphic bleed specifications.

# Included in Your Design

Tools, Components,  
& Connectors



ALLEN KEY x1

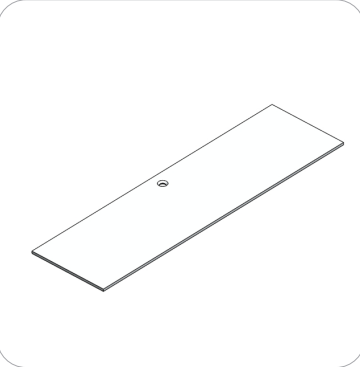

FOOT x2



SPREADER-1500 x1



FOOT SCREW x2

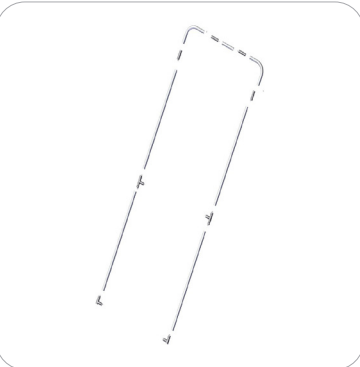

BUNGEE ASSEMBLY x1

Graphics

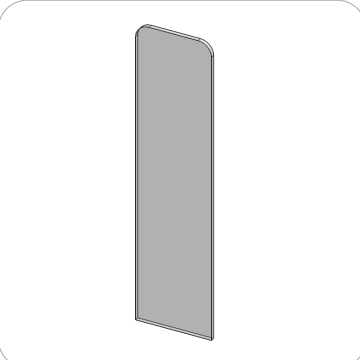

FMLT-ESS-S-1500-G x1

# Exploded View

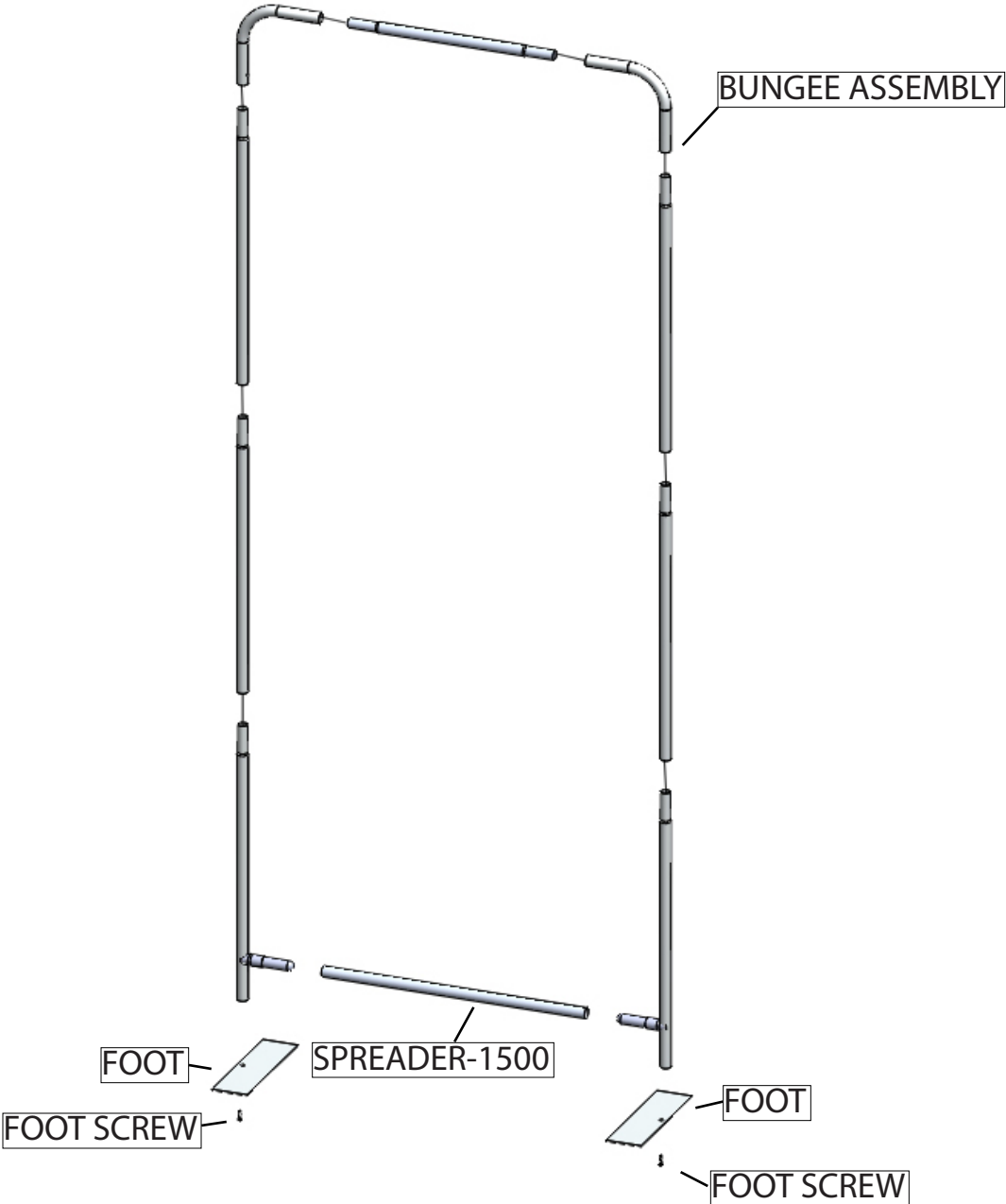

# Connection Methods

TensionLite tructures use a number of different yet simple connection methods. Your design will include one or more of the connection methods shown below. Steps within the design Assembly will reference a specific method for each connection point.

## Connection Method 1: Automatic Clip Spreader

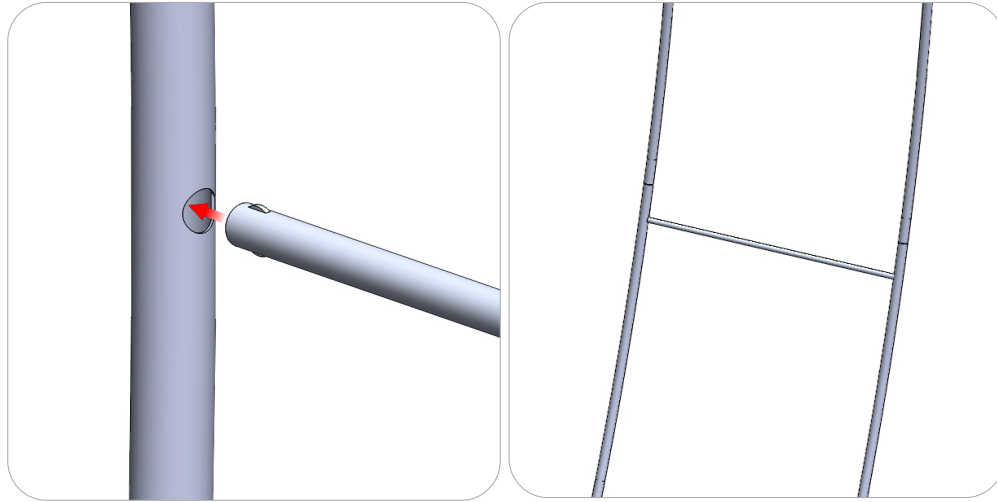

Locate the spreader with rounded clips on each end. Simply push each end of the spreader in any orientation into the holes of the center tubes in your bungee assembly. There is no need to suppress the clips by hand.

## Connection Method 2: Snap Buttons & Swage

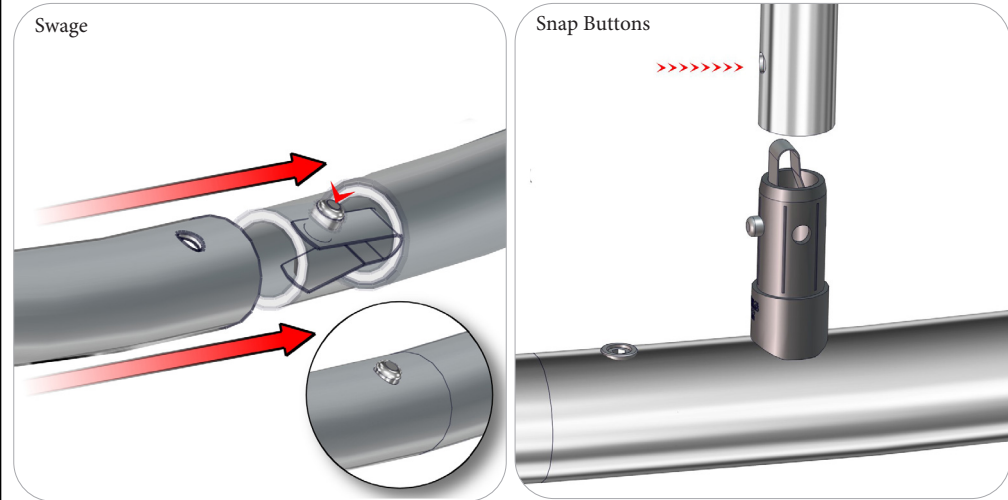

Locate the snap button on the connector or swage tube. Locate the hole on the corresponding tube. Press the snap button with your thumb and slide the tube and connector together so that the snap button snaps fully into the lock hole. To disassemble, press the snap button and pull apart.

# Design Assembly

## Step by Step Step 1.

Begin assembling your frame by applying the your SPREADER to the inside connectors. Push all tubes and connectors of the bungee assembly together to complete frame assembly.

Reference connection method 2 for further assistance.



## Step 2.

Pull your graphic over the top of the frame and zip along the bottom.

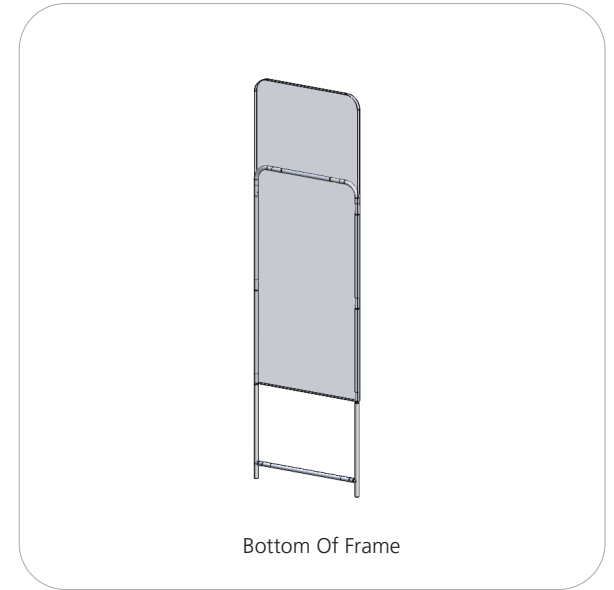

Bottom Of Frame

## Step 3.

Use your allen key to lock the FOOT SCREW through the feet and into the bottom of your frame.

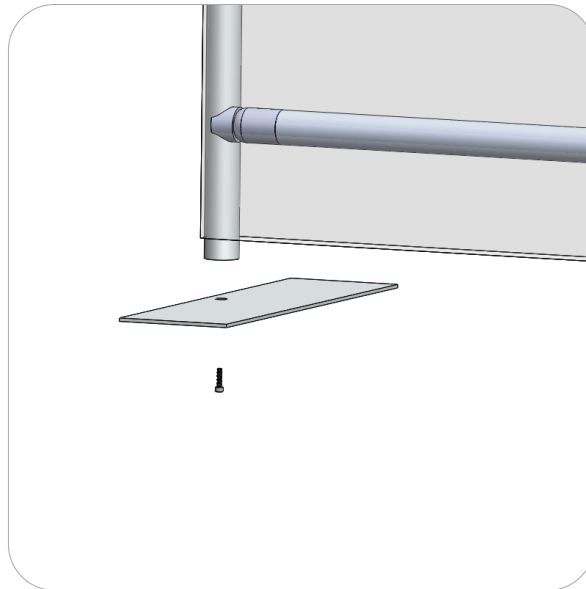
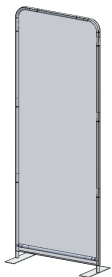

## Step 4.

Setup is complete.

